

# BEVCO®

## ASSEMBLY GUIDE FOR BEVCO 2000 SERIES CHAIRS

Your new BEVCO chair comes with four easily assembled parts:

- Base
- Vertical Back Bracket
- Seat with Control
- Back Assembly

If you have purchased OPTIONAL CASTERS with your chair, they are packaged in a separate bag in the same carton your chair was shipped in.

### TO ASSEMBLE YOUR CHAIR:

1. Remove base (A) from carton and place on floor. Remove other parts from the box.
2. The vertical back bracket (B) is packed upside down and backwards in the seat control unit (C). Loosen the handwheel, remove the vertical back bracket, and set aside.
3. Insert stem of seat (D) into base hub tube (E).
4. Rotate large bell handwheel (F) on threaded stem to select the proper height. CAUTION: There is grease on the threaded stem.
5. Tighten screw in bell handwheel (F) enough to prevent removal of seat assembly from base.
6. Install flat portion of vertical back bracket (B) into the seat control unit (C) and tighten handwheel securely.
7. Slide backrest (G) onto the curved portion of the back bracket and set back at the desired height. Tighten handwheel securely.
8. Insert optional casters into the end of each tubular steel leg (H).

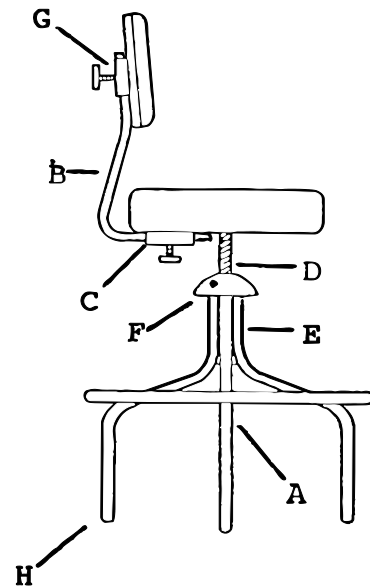

Model 2600/5

### REQUIRED MAINTENANCE:

1. Every six (6) months lightly lubricate the threaded stem with a petroleum based grease.
2. Tighten all screws and handwheels periodically.

**CAUTION:** *Failure--to perform required maintenance may void your warranty.*